



HIGH QUALITY SCALE MODEL, RESIN MODEL  
**Bristol Bulldog Mk IIA**

The Bristol Bulldog was a single seat biplane fighter of the inter-war period and one of the most famous aircraft used by the RAF during that time. The prototype Bristol Bulldog first flew on 17 May 1927, and the Bulldog Mk II entered service with the Royal Air Force with No. 3 Squadron in May 1929, replacing the Gloster Gamecock and Armstrong Whitworth Siskin fighters then in frontline use. The Bulldog served with virtually all RAF squadrons, and carried a wide variety of colorful markings. Often remembered for spectacular aerial formation displays at the annual Hendon RAF competition, the Bulldog finally disappeared from front line service in July 1937 when No.3 Squadron traded in their Bulldogs for Gloster Gladiators.

Powered by a Bristol Jupiter VIIF radial piston engine producing 490 hp, the Bulldog IIA had a maximum speed of 178 mph. The Bulldog's superb maneuverability and ease of handling made it very popular with its pilots.

A total of 441 Bulldogs of all marks were produced for the RAF. The Bulldog never saw combat with the RAF but due to its cheap sales price, several foreign customers ordered Bulldogs, including Sweden, Siam, Latvia, Japan, Denmark and Finland, with one Bulldog tested by the US Navy. The Finnish Bulldogs fought the Soviets during the Winter War, while the Spanish aircraft served at the outset of the Spanish Civil War on the Republican side.

The Bristol Bulldog was replaced in RAF service by the Gloster Gauntlet.

**TECHNICAL DATA**

Crew: 1  
 Length: 7,67 m  
 Wing span: 10,3 m  
 Height: 2,67 m  
 Empty Weight: 1000 kg  
 Engine: 1 × Bristol Jupiter VII  
 radial piston engine 490 hp (370 kW)  
 Max Speed: 287 km/h (178 mph)  
 Service Ceiling: 8930 m  
 Armament: 2 x 7,7 mm  
 Vickers machine guns  
 Bomb-load: 4 x 9 kg bombs

**Operators:**

Australia - Royal Australian Air Force  
 Denmark - Royal Danish Air Force  
 Estonia - Estonian Air Force  
 Finland - Finnish Air Force

Japan - Imperial Japanese Navy Air Service  
 Latvia - Latvian Air Force  
 Siam - Royal Siamese Air Force  
 Spanish Republic - Spanish Republican Air Force

Sweden - Royal Swedish Air Force  
 United Kingdom - Royal Air Force  
 United States - United States Navy

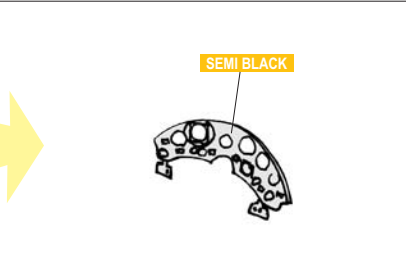
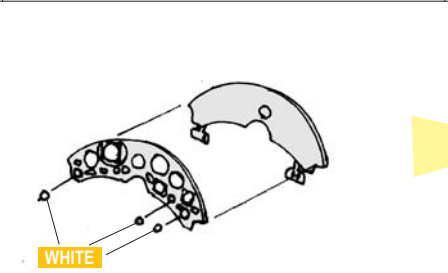
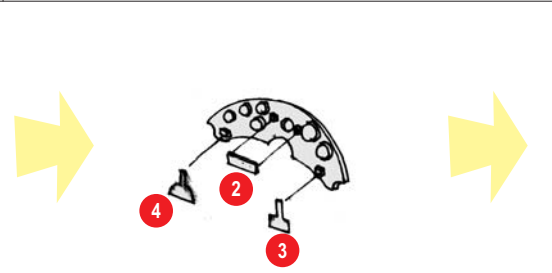
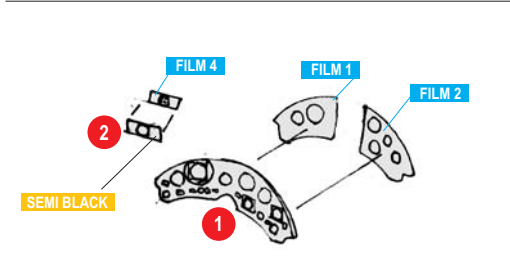
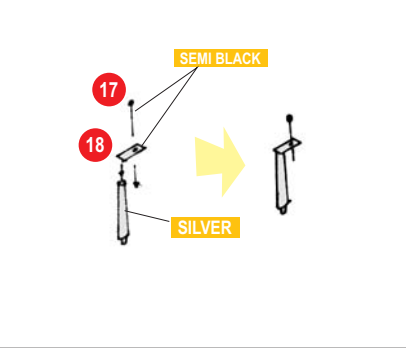
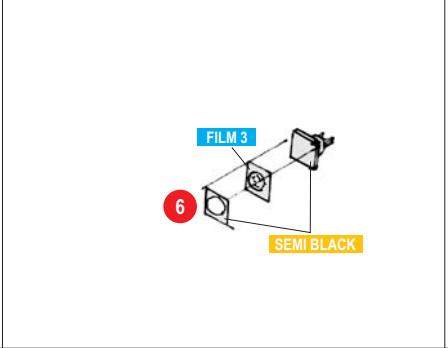
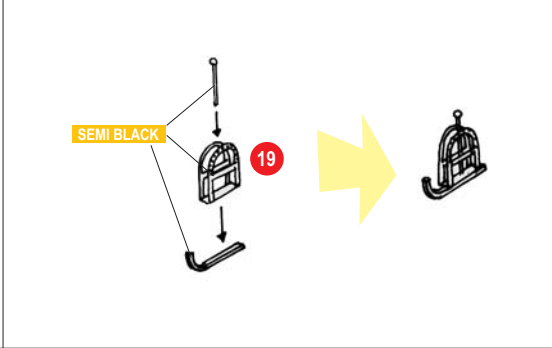
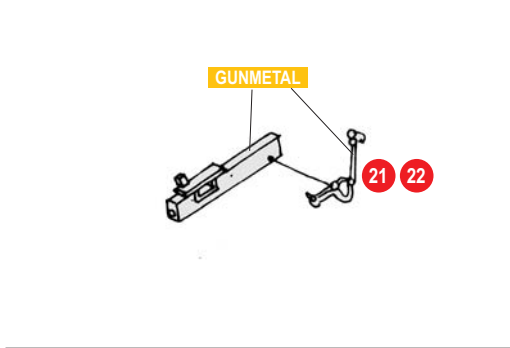
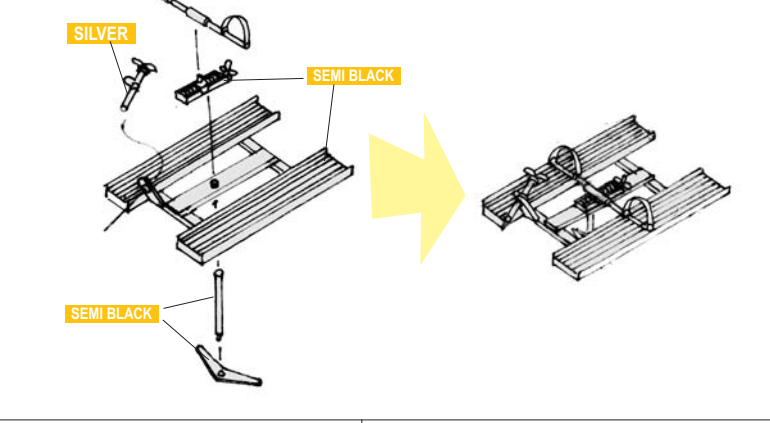
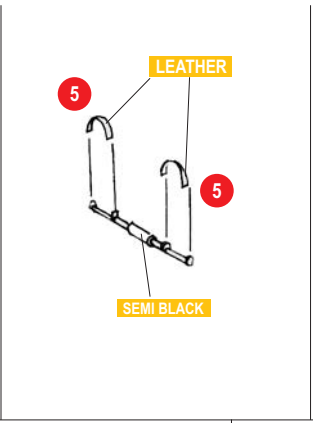
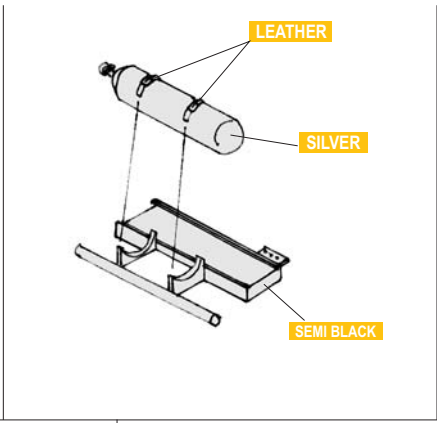
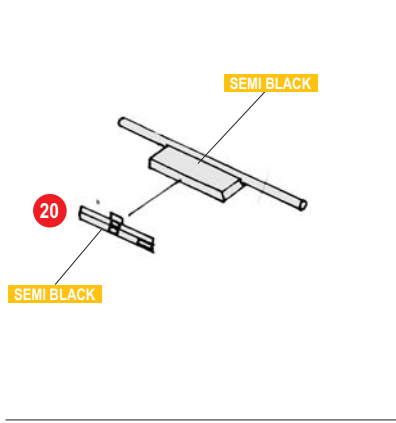

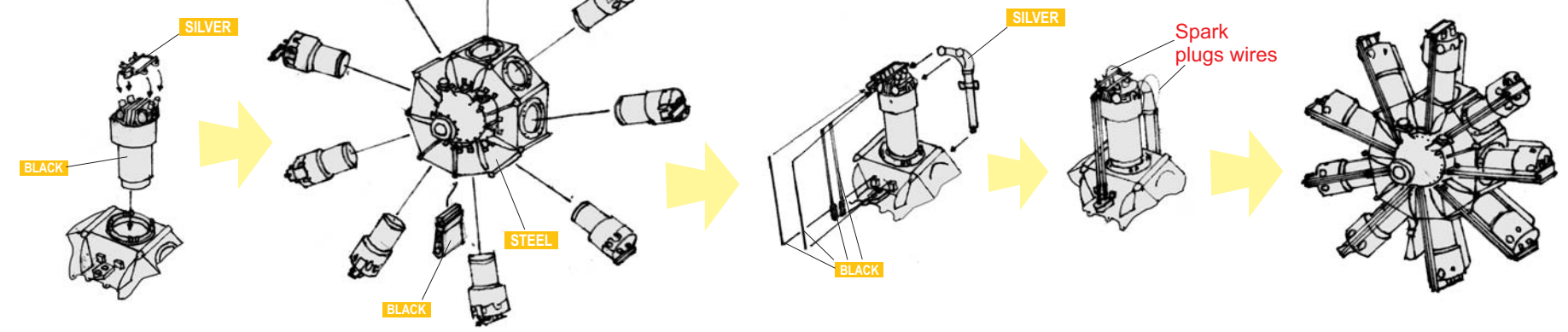
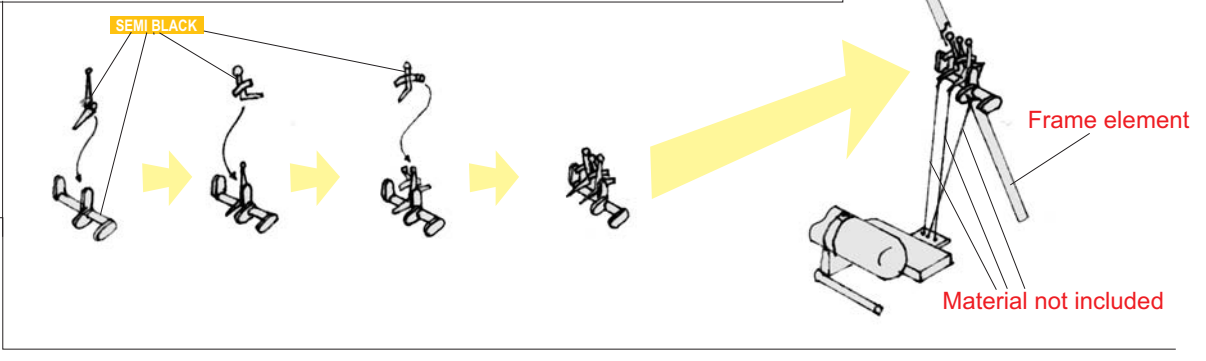
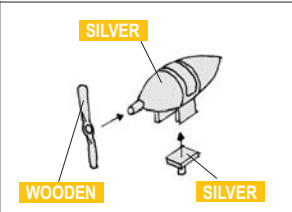
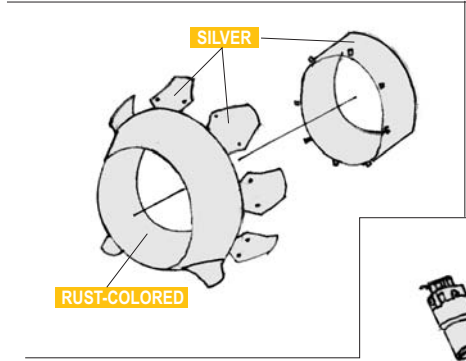
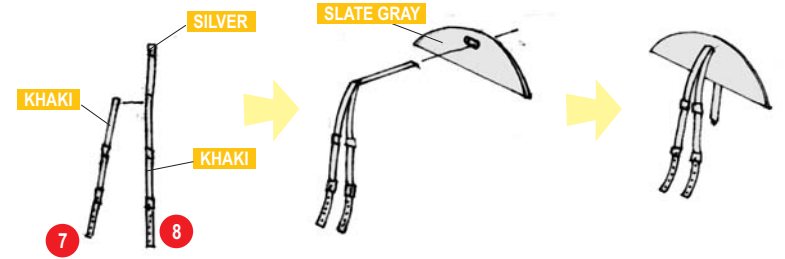
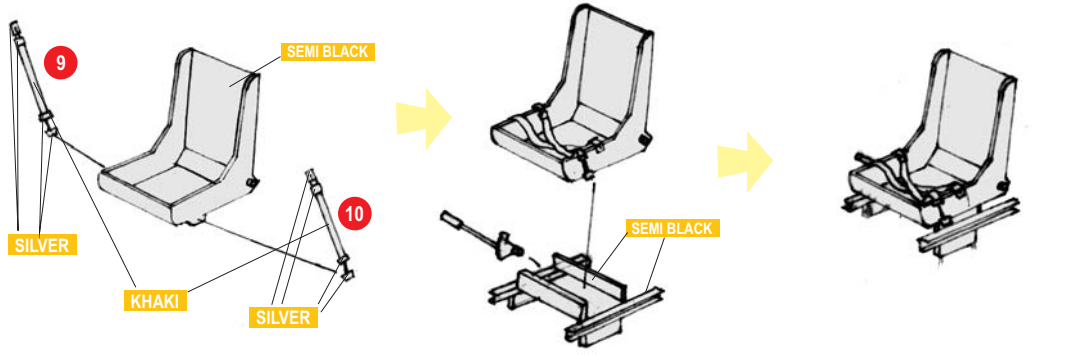

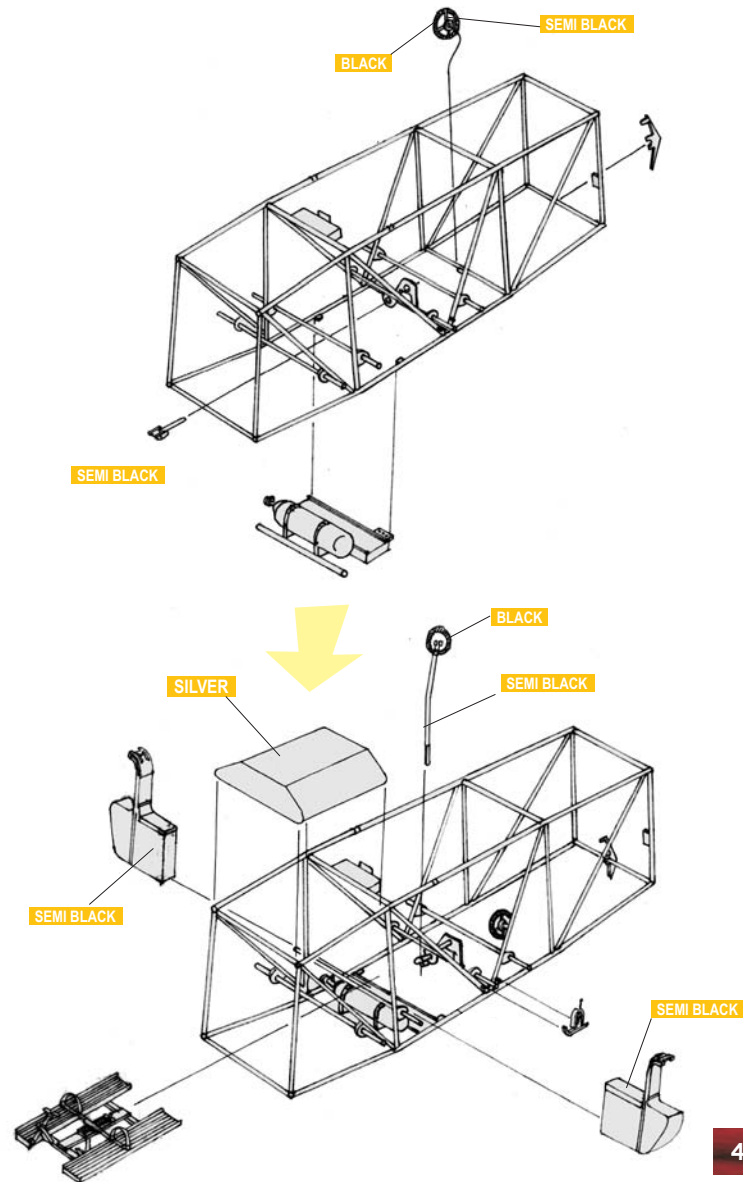
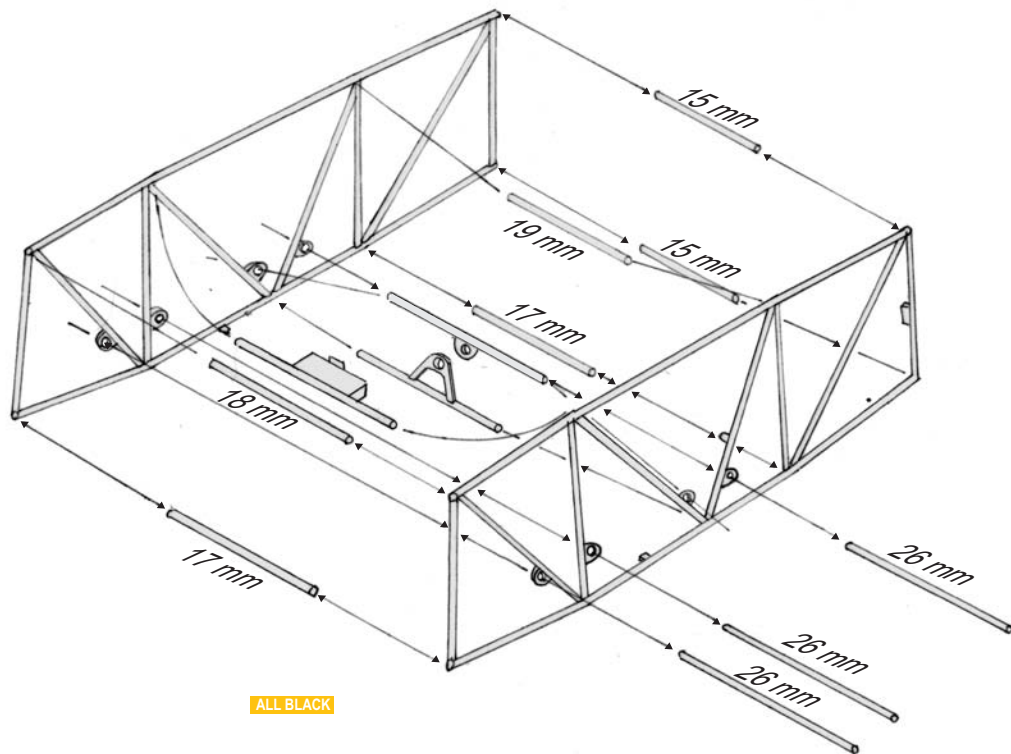

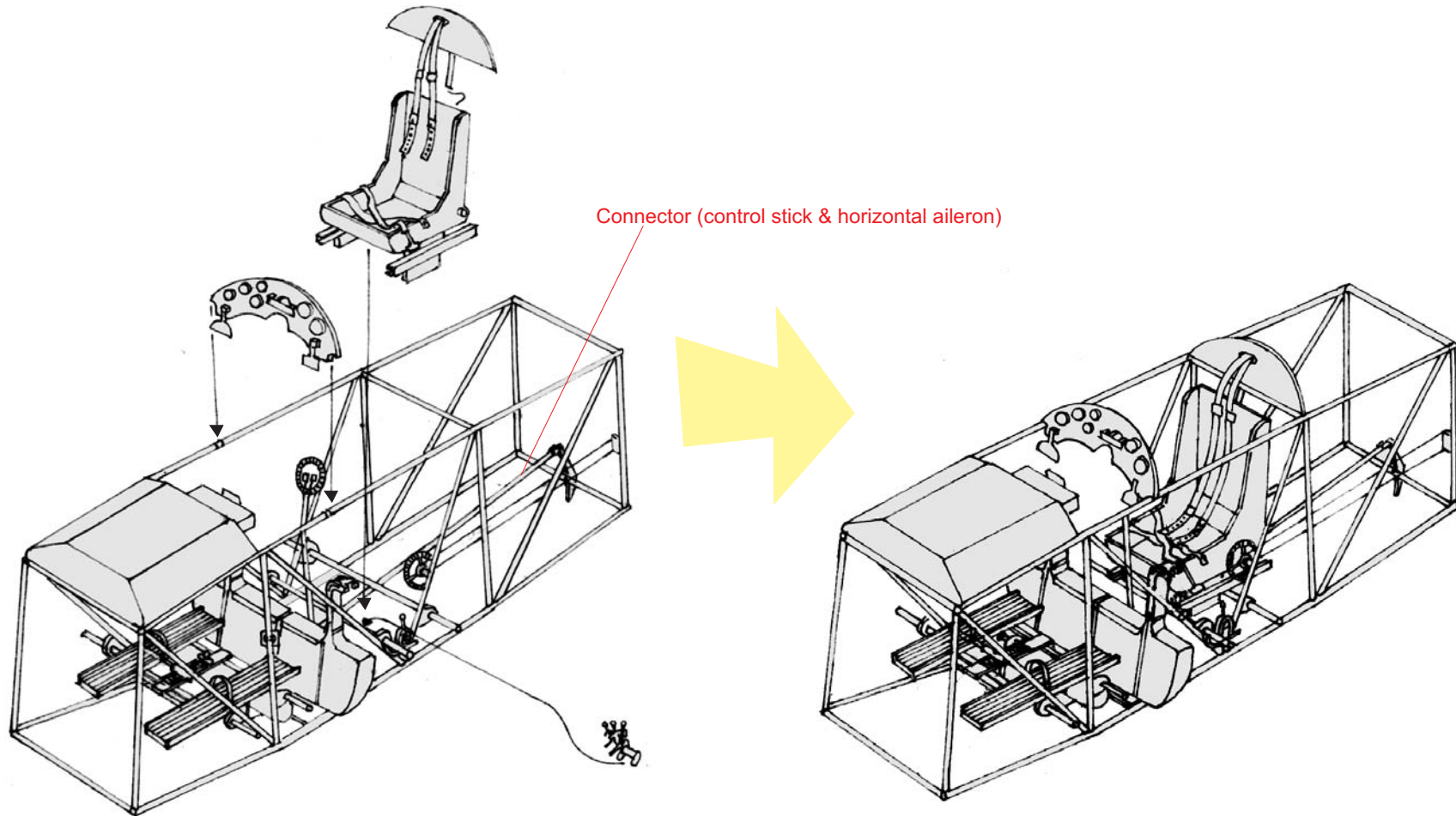

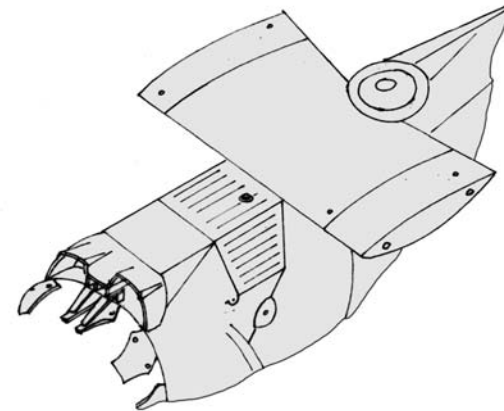
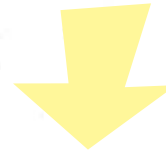
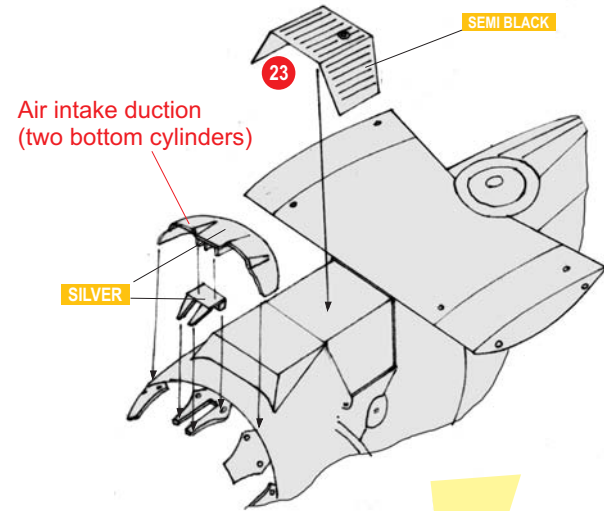
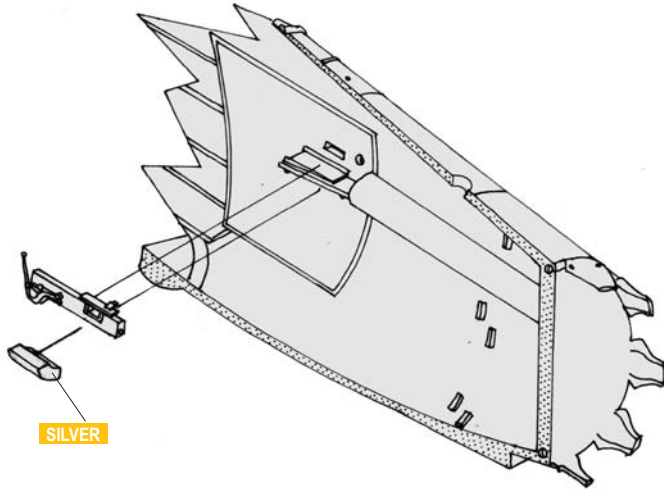
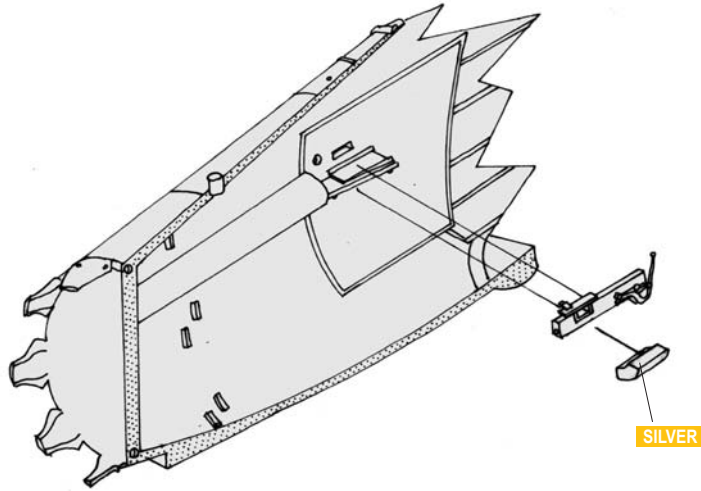

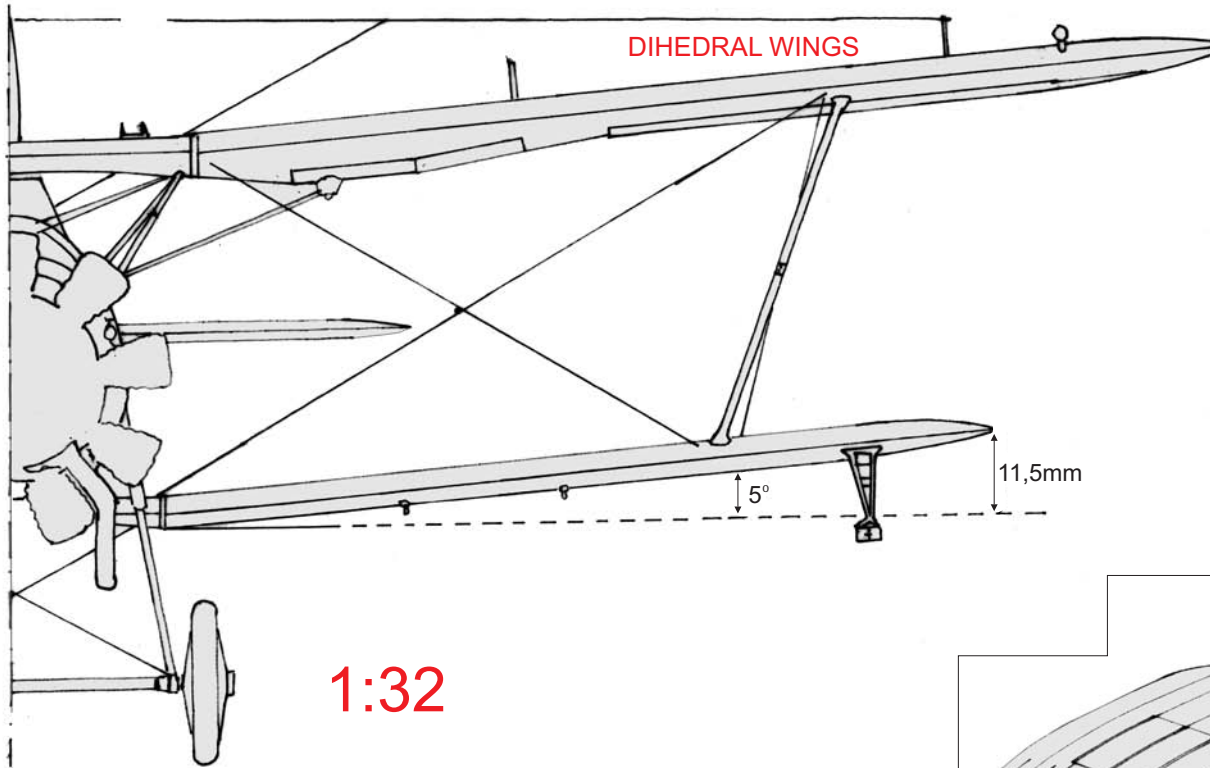

1:32

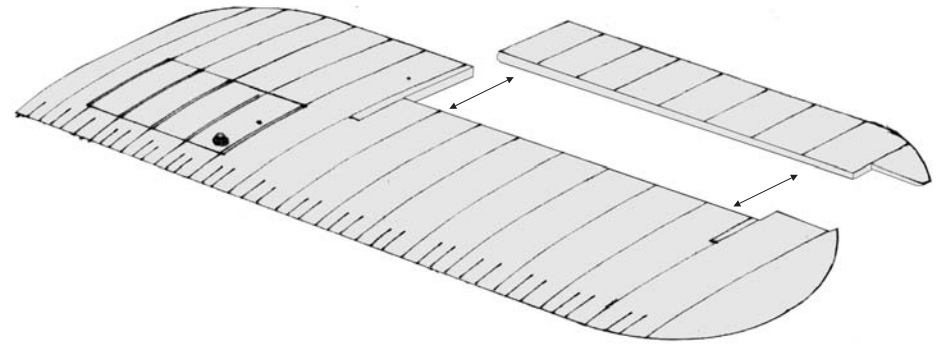
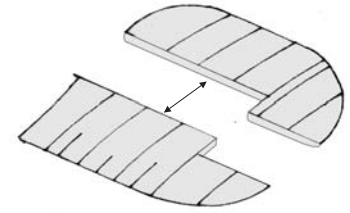

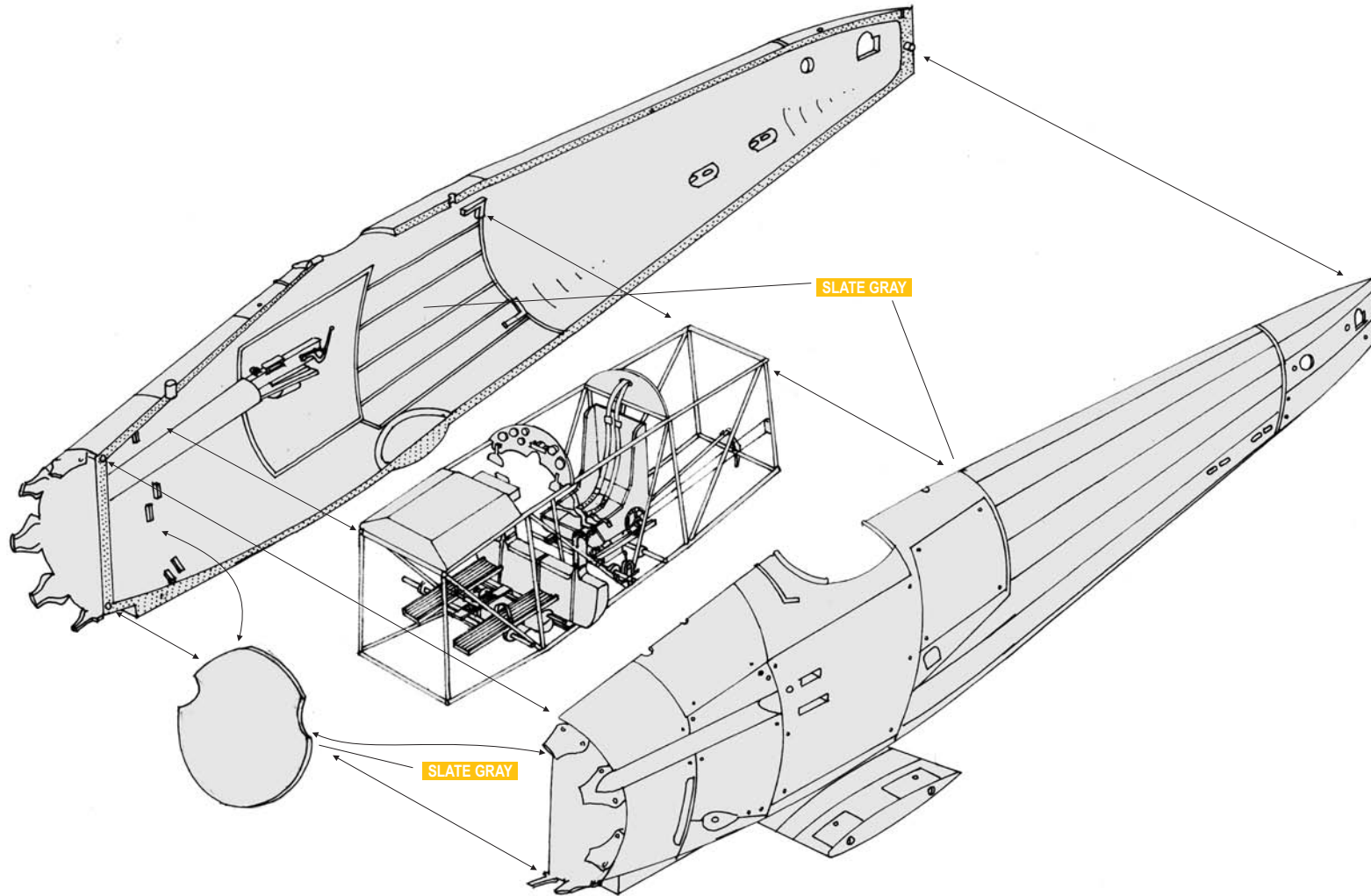



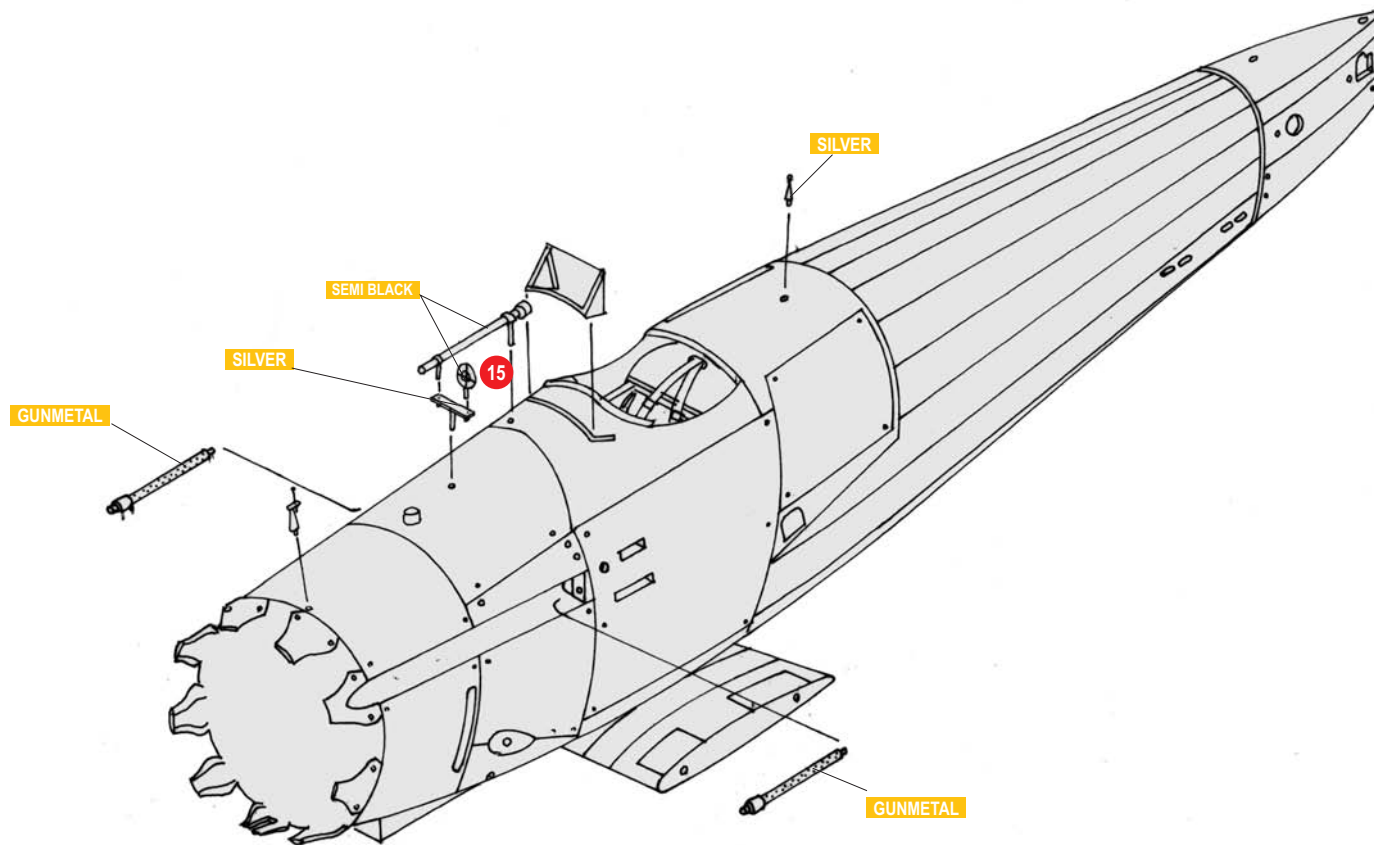

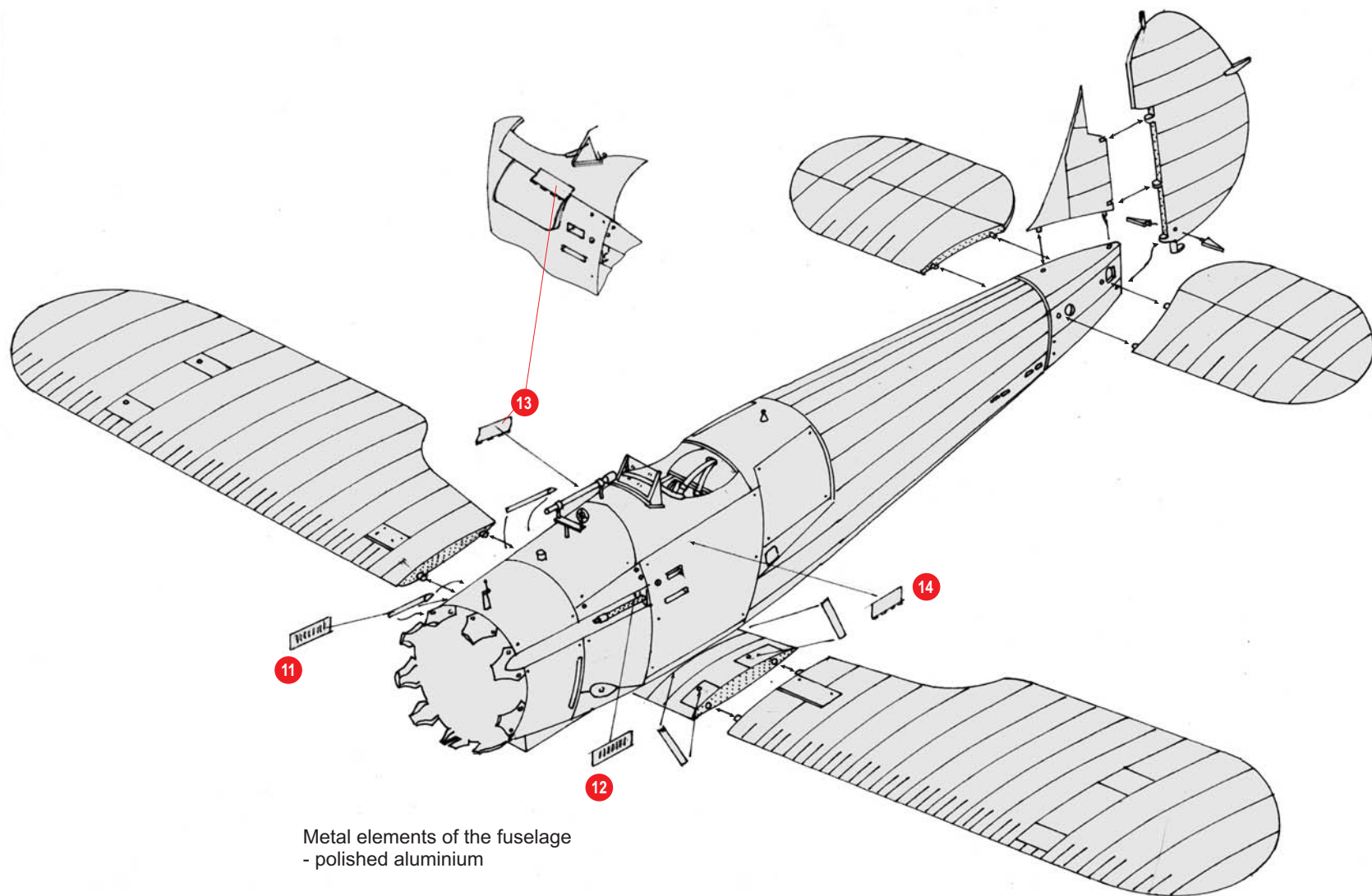

Metal elements of the fuselage  
- polished aluminium

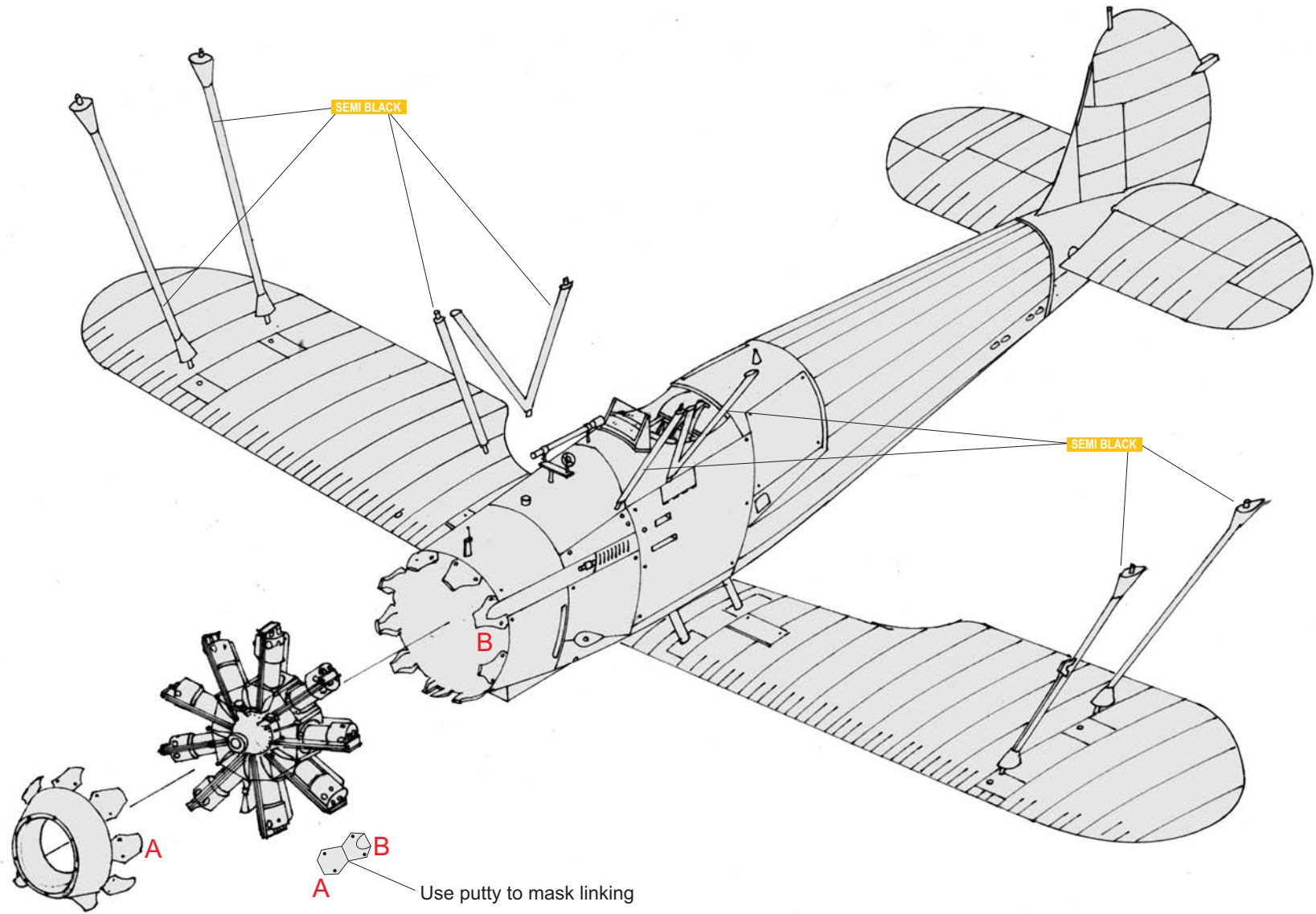

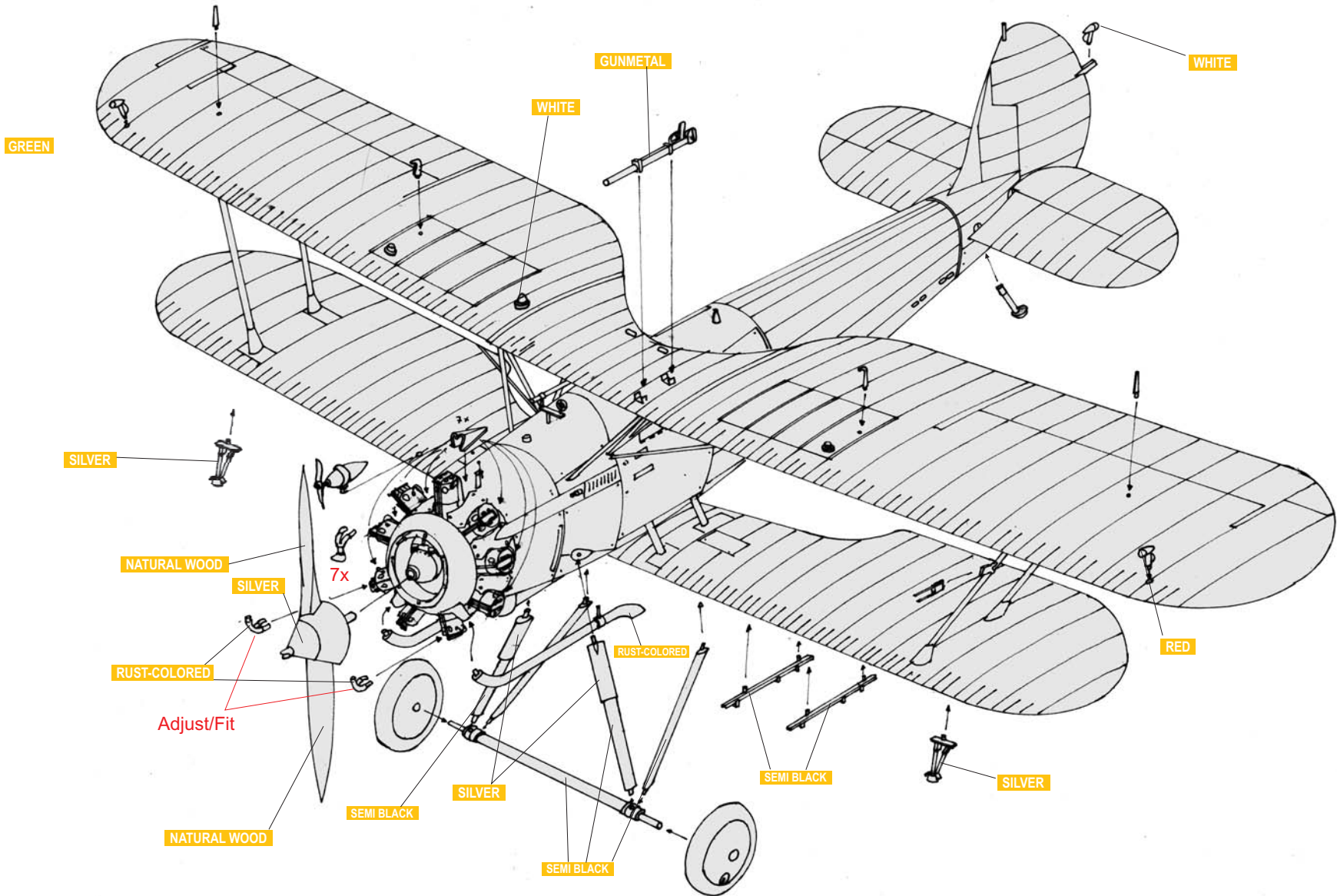

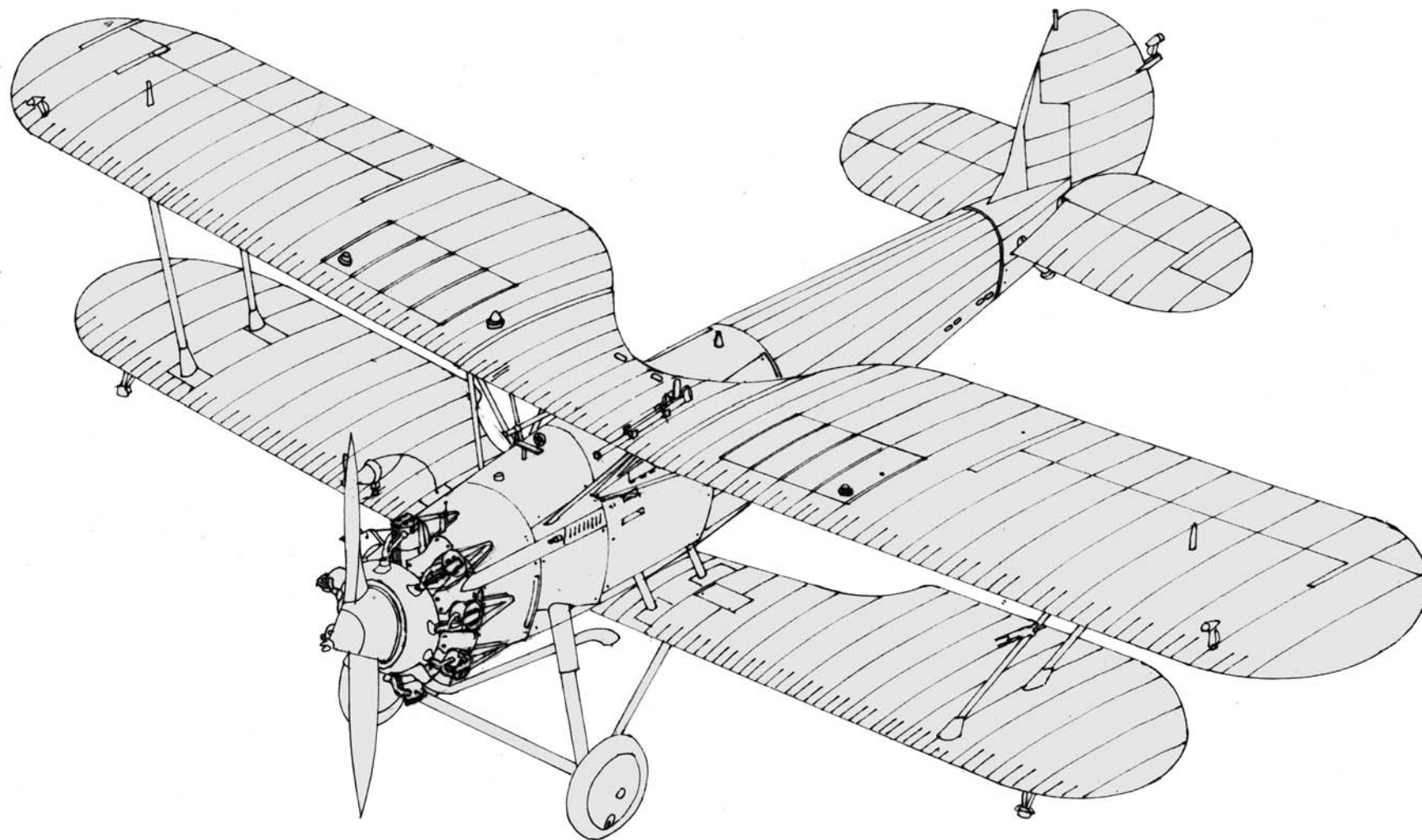

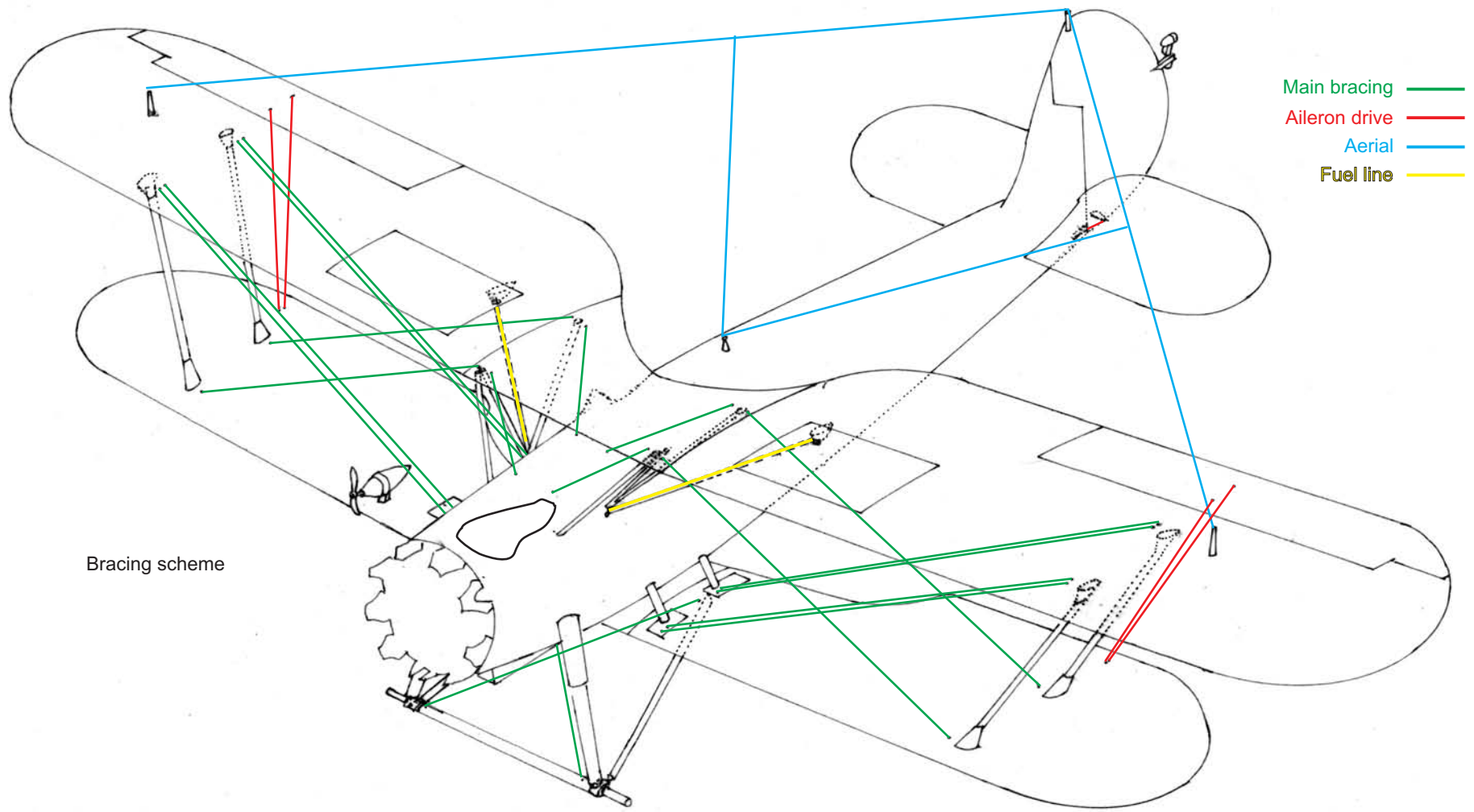

- Main bracing — green line
- Aileron drive — red line
- Aerial — blue line
- Fuel line — yellow line

Bracing scheme

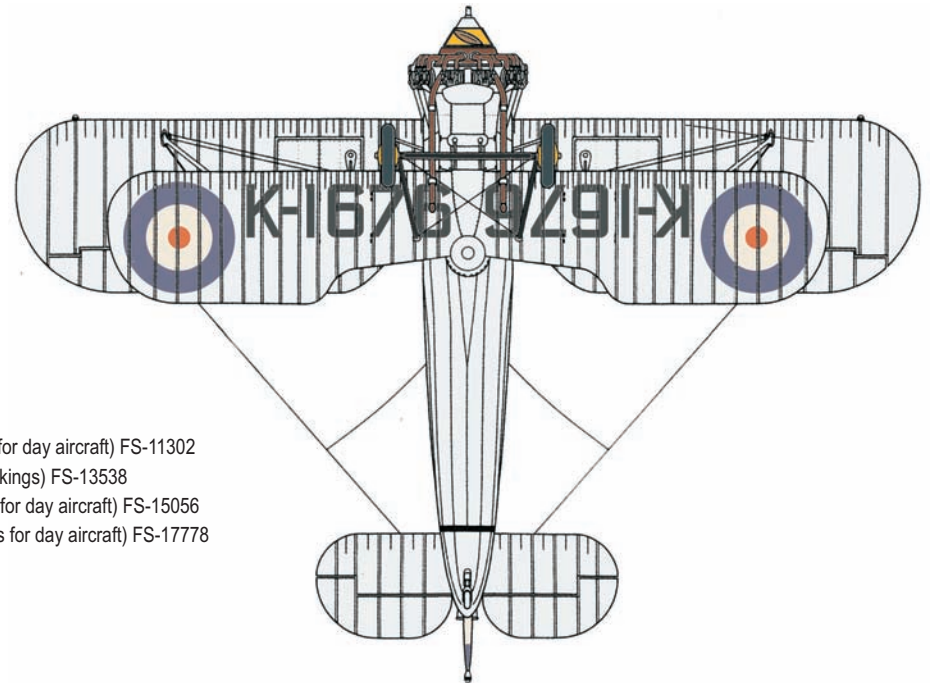
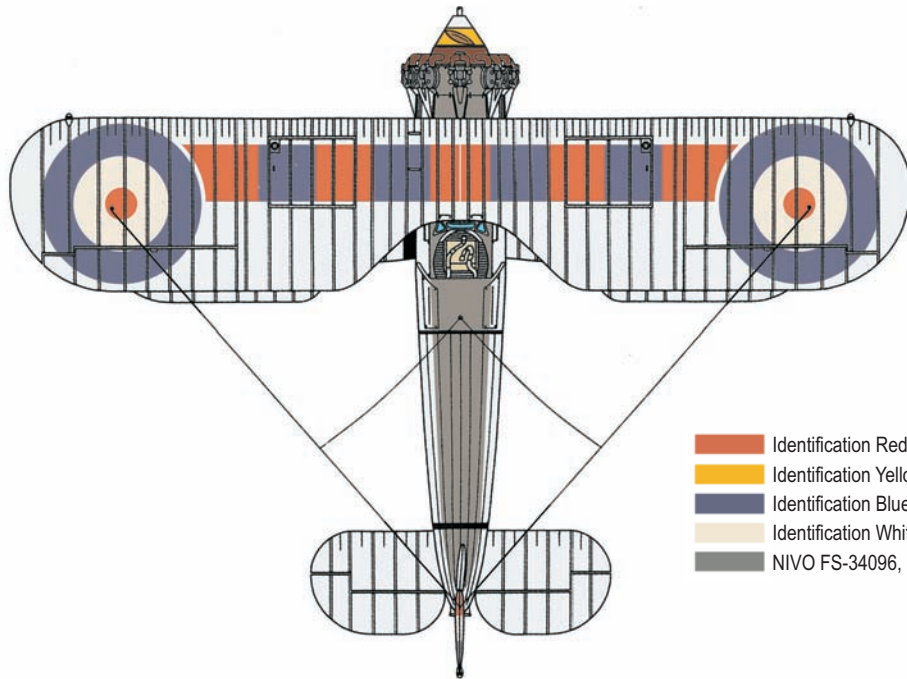

- Identification Red (Roundels for day aircraft) FS-11302
- Identification Yellow (unit markings) FS-13538
- Identification Blue (Roundels for day aircraft) FS-15056
- Identification White (Roundels for day aircraft) FS-17778
- NIVO FS-34096, 30103



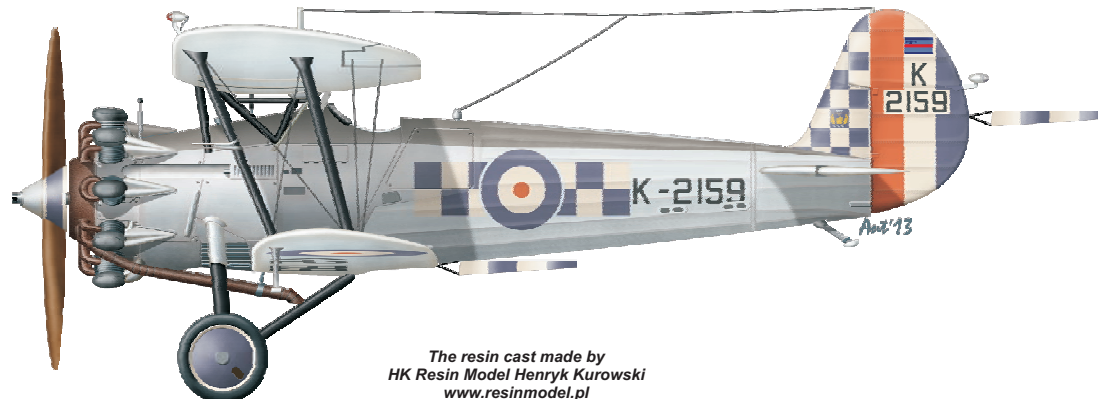
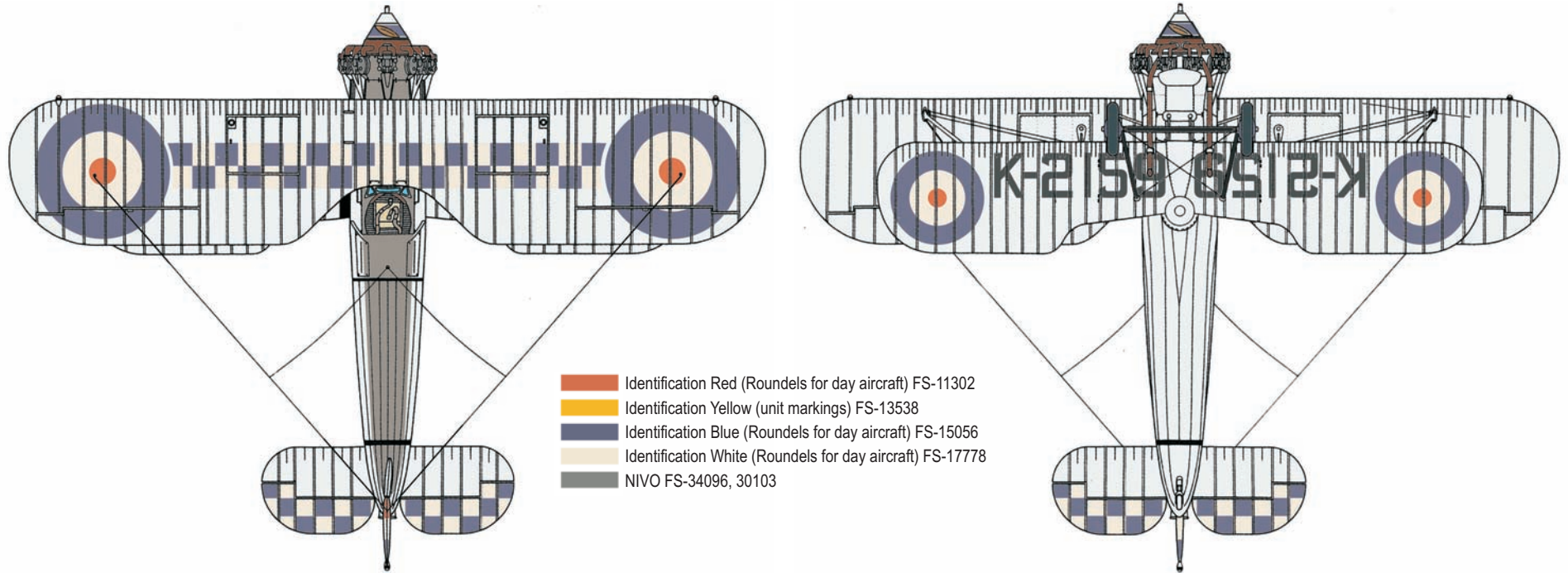

The resin cast made by  
 HK Resin Model Henryk Kurowski  
[www.resinmodel.pl](http://www.resinmodel.pl)

© Silver Wings 2013